

- CONTENTS -

	PAGE.
INTRODUCTION.	3.
CHARACTERISTICS AND SPECIFICATIONS.	4.
SAFETY.	5.
THEORY OF OPERATION.	7.
APPLICATIONS.	8.
INSTALLATION.	9.
SETTING UP THE HJ3100.	9.
OPTIONS.	10.
OPERATION.	11.
MAINTENANCE.	12.
TROUBLESHOOTING.	13.
WHERE TO GO FOR SERVICE.	14.
APPENDIX A. FILTERS.	15.
APPENDIX B. TECHNICAL INFORMATION.	16.
OUTLINE DRAWINGS.	16.
WIRING DIAGRAMS.	17.
APPENDIX C. ACTIVATED CARBON.	18.
APPENDIX D. WARRANTY INFORMATION.	20.
ILLUSTRATIONS AND DIAGRAMS.	
THE HAKKO HJ3100	FRONTISPIECE
FIGURE 1. THE HAKKO FILTER SYSTEM.	7.
FIGURE 2. REQUIRED CLEARANCES FOR INSTALLATION.	9.
FIGURE 3. ILLUSTRATED PARTS BREAKDOWN, HJ3100.	12.
FIGURE B-1. OUTLINE DRAWINGS.	16.
FIGURE B-2. WIRING DIAGRAMS.	17.
TABLES.	
TABLE I. SPECIFICATIONS, GENERAL.	4.
TABLE II. SPECIFICATIONS, ENVIRONMENTAL.	4.
TABLE C. ACTIVATED CARBON.	19.



AMERICAN HAKKO PRODUCTS, INC. RESERVE THE RIGHT TO CHANGE THE SPECIFICATIONS CONTAINED IN THIS MANUAL AT THEIR DISCRETION AT ANY TIME, WITHOUT NOTICE.

For the latest specifications pertaining to the Hakko HJ3100, or any Hakko product, contact your nearest authorized Hakko distributor, your regional Hakko manager, or American Hakko Products' Customer Service.

Additional copies of this manual or other Hakko literature may be obtained from:

American Hakko Products, Inc.
Customer Service
28920, Avenue Williams
Valencia, California 91355
USA

Telephone: (661) 294-0090 Toll free: (800) 884-2556 Facsimile: (661) 294-0096

E-mail:

Customer Service: support@hakkousa.com
Technical: engineering@hakkousa.com
Marketing: marketing@hakkousa.com

◀◀NOTE▶▶

Ù Ø Ó Ò Á Ú Ò Á Ó Y Ø Á W Q Ø V Ø Á R U V W Ù X Ö W R Ú U V È Á
Á

KEEP THIS MANUAL WHERE IT IS READILY AVAILABLE FOR REFERENCE.

INTRODUCTION.

Congratulations! You have purchased the most adaptable and efficient small fume extraction system on the market - the Hakko HJ3100. To get the most out of your system, please read this manual thoroughly before installing and operating the HJ3100.

◀◀NOTE▶▶

American Hakko Products strongly recommends that especial attention be given the sections on 'Safety and Applications' and 'Operation'.

THE PURPOSE OF FUME EXTRACTION.

Soldering work involves both metallic and organic compounds. The solders themselves contain, besides tin and lead, various levels of zinc, arsenic, cadmium, antimony and other metals. Fluxes necessary for soldering contain activators to enhance their cleaning properties; these activators are typically organic acids. Such compounds, when heated, release byproducts of incomplete combustion, which in turn can contain noxious fumes, particulate matter, aerosols, and gasses. Prolonged breathing of these contaminants can lead to both short- and long-term operator irritations and illness.

THIS MANUAL.

This manual provides the user with the basic information required to properly use and maintain the Hakko HJ3100 fume extraction system. Spare parts and accessories are described in the Appendix.

THE HAKKO HJ3100.

The Hakko HJ3100 fume extraction unit is designed expressly for use at soldering stations. It extracts the contaminated air directly at the source. This contributes to a healthier and more productive work environment, and assists in achieving recommended health and safety requirements for local exhaust ventilation and contaminant removal.

Salient features of the Hakko HJ3100 include:

- A heavy-duty, maintenance-free brushless motor adaptable to either 100/125 or 220/230VAC, 50/60 Hz
- A three-stage HEPA filtering process
- One to four station fume extraction capability
- A wide range of accessories (see Hakko publication 2001-FEA-1)

Six versions of the Hakko HJ3100 are available:

The basic HJ3100, with pre-filter and HEPA/carbon filter only. Comes with 999-172 two-port cover. This version is for 100/115VAC applications.

The HJ3100-01, an HJ3100 equipped with a 230VAC motor and supplied with two six-foot lengths of 3" neoprene duct (999-186), two rectangular hoods (999-138) and two packets of hose clamps, two per packet (999-169).

The HJ3100-02, a basic HJ3100 supplied with two six-foot lengths of 3" neoprene duct (999-186), two rectangular hoods (999-138) and two packets of hose clamps, two per packet (999-169).

The HJ3100-03, a basic HJ3100 equipped with a 230VAC motor.

The HJ3100-04, a basic HJ3100 but fitted with the 999-182 carbon filter in lieu of the 999-137 HEPA/carbon filter. This version is not to be used in flammable or explosive atmospheres, or for removing odors arising from the use of flammable or explosive chemicals; Appendix C provides a list of common industrial chemicals against which an activated carbon filter is effective.

The HJ3100-05, same as the basic HJ3100 but with the 999-173 four-port cover.

AMBIENT OPERATING HUMIDITY	90% RELATIVE HUMIDITY MAXIMUM (NON-CONDENSING)
STORAGE HUMIDITY	90% RELATIVE HUMIDITY MAXIMUM (NON-CONDENSING)

SAFETY.

READ, UNDERSTAND AND RETAIN THIS SECTION.

For maximum operator and workplace safety, as well as optimum performance, be sure to follow all safety, application and maintenance instructions and guidelines in this manual. Where material safety data sheets or other relevant information is available regarding the substances and equipment generating the fumes to be extracted, read them carefully and compare the data contained therein with the warnings and limitations in this manual.

DISCLAIMER.

American Hakko Products hereby disclaims all responsibility for any personal injury, property damage, fine, citation, or penalty imposed by any government or private entity resulting from any use, misuse or misapplication of this product; for any failure of the user to regularly maintain the product according to the instructions contained herein; or any failure of the user to adequately monitor fume extraction exhaust air and the ambient workplace air for the presence of harmful levels of gases, fumes and particulates.

COMPLIANCE WITH APPLICABLE ENVIRONMENTAL AND PERSONNEL SAFETY REGULATIONS IS THE SOLE RESPONSIBILITY OF THE USER.

WARNING.

FAILURE TO COMPLY WITH THE APPLICATION AND MAINTENANCE INSTRUCTIONS, FILTER REPLACEMENT SCHEDULES, MONITORING RECOMMENDATIONS AND SAFETY GUIDELINES GIVEN IN THIS MANUAL, OR WITH OTHER RELEVANT PRODUCT SAFETY INFORMATION SUCH AS MATERIAL SAFETY DATA SHEETS PROVIDED WITH THE SUBSTANCES AND EQUIPMENT GENERATING THE FUMES TO BE EXTRACTED MAY RESULT IN RISK OF SERIOUS INJURY, FIRE OR EXPLOSION.

SAFETY GUIDELINES.

WARNING

Fume extraction systems *are not to be used as substitutes for personal protective devices* such as respirators for removing substances such as carbon monoxide, methane, ethylene, acetylene and other potentially hazardous or noxious gases. Failure to use such personal protective devices may result in serious injury or death. If in doubt, consult your industrial hygienist or American Hakko Products.

For safe and effective performance, American Hakko recommends these guidelines be followed:

1. HEPA filters - hazardous particulate matter

The 999-137 filter used in the Hakko HJ3100 is certified to be a 'hospital grade' HEPA-type filter². HEPA (High Efficiency Particulate Air) filters will become loaded with particulates during normal operation. It must be replaced at regular intervals to ensure proper operation. The level of use, and the amount and composition of the contaminates peculiar to a given application, will dictate the frequency of replacement. As the filter becomes loaded, air-flow through the system will be reduced; this will eventually become noticeable to operators at the several stations being serviced.

The exhaust air from the Hakko HJ3100 and the ambient air in the workplace should be monitored, using appropriate and adequate measuring and detection devices, to guarantee compliance with applicable OSHA and NIOSH regulations.

2. Particle filters.

American Hakko offers the 999-178 cellulose particle filter as an option for the HJ3100. This filter is intended for use in grinding and shaping operations where dust and chips are produced. It is rated at 85% ASHRAE against particles of 1 micron and larger in size. The particle filter can be cleaned and reused up to five times; the preferred method of cleaning



² Hospital grade filters have efficiencies greater than 95% per MIL-STD-282.

is to vacuum out the detritus with an industrial vacuum cleaner. It is possible to clean the filter with water or compressed air. If that is the method of choice, take extreme care lest the debris find its way into the operator's eyes or the local aquifer.

3. Activated carbon filters.

The standard filter used in the Hakko HJ3100 contains an activated carbon element built into the filter. It, too, will become saturated with adsorbed contaminants. The activated carbon portion of the main filter unit is designed to last the life of the main HEPA filter; however, if the fumes being extracted are other than soldering flux fumes, measuring the exhaust air for the presence of such contaminants will indicate when this portion of the filter is depleted.

Hakko also offers an activated carbon filter, part number 999-182, for applications where odor removal is the prime consideration; this is the primary filter in the HJ3100-04. This filter should be used with a pre-filter, to keep particles out of the main filter. Refer to Appendix C.

Both carbon filters have an adsorption rating of 80-85%.

4. Pre-filters.

The standard pre-filter, 999-136, is a nonwoven polyester pad with a surface area of 80 square inches, rated at 86% arrestance. It removes coarse particles from the intake air. Because it traps these particles before they can reach the main HEPA/carbon filter, it will become clogged far more rapidly. It will require more frequent replacement than will the main filter; its useful life depends upon use and the nature of contaminants being removed.

The extended service pre-filter, 999-201, is made of a pleated cellulose medium with a surface area of approximately 550 square inches. It is specially recommended for use with grinding and shaping operations.

5. Flammable vapors and gases.

If flammable vapors or gases (e. g. isopropyl alcohol used for cleaning) are present in the workplace air, even in small concentrations, they will be adsorbed by the filters. The user has the responsibility of ensuring that such vapors or gases do not constitute a personnel hazard.

-DANGER!-

NEVER USE THE HAKKO HJ3100 TO EXTRACT FUMES FROM HIGHLY FLAMMABLE LIQUIDS AND GASES!

THERE IS A SERIOUS RISK OF SEVERE INJURY OR DEATH DUE TO EXPLOSION OR FIRE.

Certain airborne contaminants, when in contact with activated carbon, can undergo chemical reactions resulting in heat. The Hakko HJ3100 **MUST NOT** be used to extract fumes from these substances.

6. Disposing of used filters.

All used filters must be handled with care. They may contain hazardous substances such as lead, flux residue, asbestos, organic compounds, or airborne pollutants extracted from the ambient air. Always use appropriate personal protection equipment (protective gloves, respirators, and the like) when handling used filters, and dispose of them in plastic containment bags. Local regulations will dictate the means of disposal.

Filters containing potentially hazardous substances must be handled with extreme caution. Use the material safety data sheet(s) pertinent to the substance(s) and dispose of such filters per instructions from your local environmental authority.

7. Noise suppression.

Should noise suppression be an issue, two accessories are available for reducing the volume of sound emitted by the HJ3100:

The 999-171 muffler provides a sound reduction of 5 dBA (about one-half) across the band of audibility. It does not reduce air -flow.

The 999-210 silencer provides a sound reduction of 10 dBA (about three-quarters) across the band of audibility. It reduces air-flow by less than 8%.

THEORY OF OPERATION.

The HJ3100 is a *high-mass flow, low-vacuum* system, which means that it depends upon air flow across the work area for effective fume extraction. Contaminated air is captured from the workplace surrounding the soldering station by the hood or hoods, and transferred to the HJ3100 by flexible or rigid ducts. Within the HJ3100, two filters, comprising three stages of filtering, remove the contaminants from the air. The purified air is then returned to the area where the HJ3100 is located.

Because the HJ3100 depends upon mass flow for its operation, free flow of air must be guaranteed between the station where fumes are to be extracted and the main filter unit. The maximum length of flexible duct recommended for greatest efficiency is 25 feet of unimpeded 3" duct. The maximum length of rigid duct is not significant, as this duct does not materially restrict air flow.

FILTERING.

There are three stages of filtering (Figure 1, below, illustrates the Hakko filtering process):

- The *pre-filter* is made of a treated polyester material. It removes coarse particles, such as dust, that may be suspended in the air, and thus extends the service life of the HEPA filter. Particles as small as 30 microns diameter are trapped by the pre-filter. It should be checked at least once a week, and replaced when clogged. Under normal conditions³ this will be every two to three weeks.
- The *main HEPA/carbon filter* purifies the air in two ways:
 - The *HEPA filter* is a special case of a particulate filter. It incorporates a pleated fiberglass paper medium, thus providing the greatest amount of surface area within the volume of the filter case. It is rated as a 'hospital grade HEPA filter' - greater than 98% efficiency per the DOP test - and removes particles as small as 0.3 micron.
 - The activated carbon filter adsorbs gases and odors from the filtered air. Adsorption efficiency is 80%.
 - The main filter should be changed every four months or 640 hours of use, whichever comes first.
- The *carbon filter* adsorbs gases and odors from the filtered air at an adsorption efficiency of 84%. It has a much larger surface area than the carbon portion of the standard HEPA/carbon filter, hence a longer life. It should always be used with a pre-filter to preclude being clogged by particulate matter.
- The particulate filter removes particles of 1 micron diameter and larger from the air. See page 5.

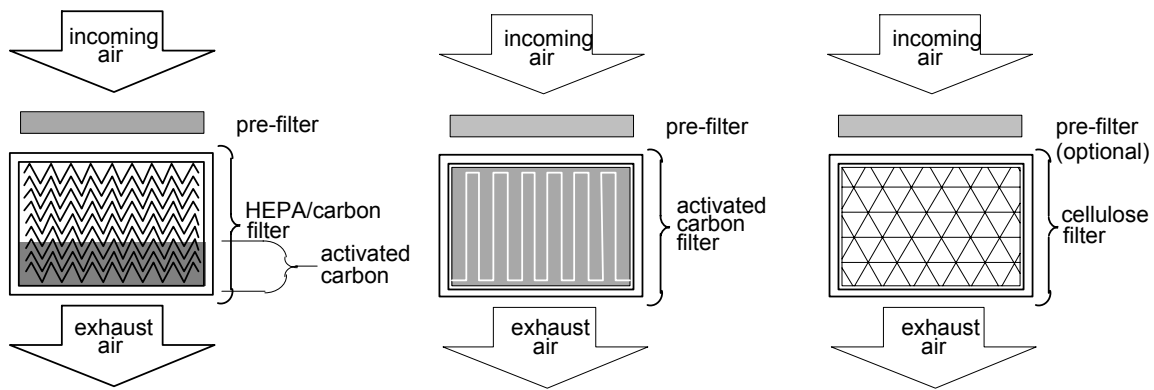

Figure 1a.
The standard Hakko filter.

Figure 1b.
The Hakko activated carbon filter.

Figure 1c.
The Hakko particulate filter.

APPLICATIONS.

SOLDERING STATION FUME EXTRACTION.

The Hakko HJ3100 is specially engineered to remove particulate and gaseous contaminants from soldering work stations. As many



³Normal conditions' - Defined as single-shift operation, eight hours per day, five days per week.

as four stations may be serviced by one HJ3100, depending upon the accessories selected. The HJ3100 is a high-mass flow, low-vacuum system, which means that it uses air flow across the work area for effective fume extraction. The user may choose from the accessories and setups shown in Hakko publication 2001-FEA-1.

PARTICULATE EXTRACTION FROM MACHINING OPERATIONS.

The Hakko HJ3100, in conjunction with the 999-178 filter, can be used to remove fine particles and dust from machining and grinding operations, provided that these particles and dust do not contain, or are not coated by, flammable or corrosive materials. The pre-filter must be checked more frequently when the HJ3100 is so used with a standard HEPA/carbon filter.

INSTALLATION.

SETTING UP THE HJ3100.

These installation instructions and descriptions are perforce general, because no two installations are the same. The sample descriptions and diagrams that follow are intended to give the user an indication of the several ways in which the Hakko HJ3100 may be used. American Hakko Products will be pleased to help you arrive at the appropriate layout and choice of accessories to fit your requirements.

Basic installation.

The Hakko HJ3100 may be installed in any location, and at any orientation, that allows access to the power switch, and to the filters when servicing is required. Figure 2, below, gives the minimum clearances required for installation. Following is a basic check list. Before operating the Hakko HJ3100, take note of these simple instructions:

1. Place the Hakko HJ3100 in a convenient location near an appropriate electrical outlet.
2. Ensure that exhaust air from the HJ3100 will not stir up unwanted dust, or adversely affect nearby operations.
3. Allow sufficient clearance to remove the top cover for access to the filters. See figure A-1 for an outline drawing of the unit.
4. Before attaching accessories to, or starting, the HJ3100, remove the top cover and verify that all filters are properly positioned.
5. If noise in the work area is a concern, attach either a 999-171 muffler or 999-210 silencer to the exhaust grille of the HJ3100. The 999-171 will reduce the output sound level by 5 dBA; the 999-210, by 10 dBA.

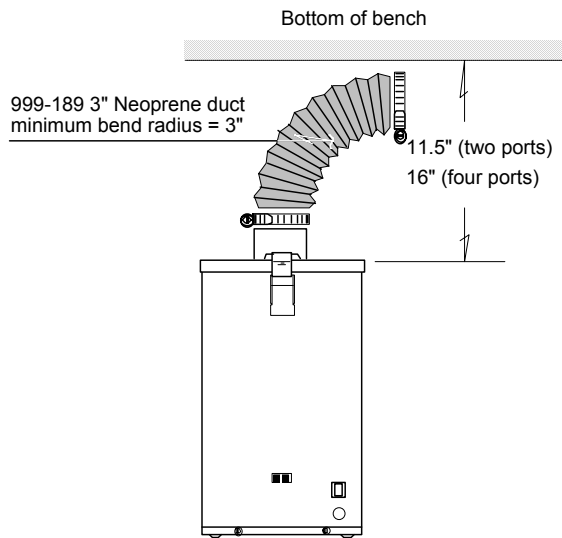

Figure 2.
Required clearances for installation.

OPTIONS.

The standard HJ3100 comes without any accessories, so the user can select those most suitable to the installation. Refer to Hakko publication 2001-FEA-1 for further information on accessories, kits and installation. Ask your Hakko representative or American Hakko Products for information.

For most applications, American Hakko recommends a maximum of six feet of hose per side for maximum efficiency, although longer runs may be used effectively.

HELPFUL HINTS FOR ALL INSTALLATIONS.

1. Be sure that all hose clamps (e. g. 999-169) are firmly tightened.
2. Be sure that all bench clamps (e. g. 999-188) are firmly tightened.
3. Be sure that all hoods are securely attached to their respective ducts.
4. If reducers are used (e.g. Fig. 7), put them as close as possible to the air intake (hood or other attachment).

Electrostatic discharge protection.

Although the probability of electrostatic discharge from the Hakko HJ3100 fume extraction system is small, many ESD-safe accessories are provided for use where such protection is a concern. Refer to Hakko publication 2001-FEA-1 or ask your Hakko representative or American Hakko Products for information.

As these accessories are conductive, setting up requires that there be no break in the circuit from the collecting device to the main body.

OPERATION.

©1997, AMERICAN HAKKO PRODUCTS, INC.
ALL RIGHTS RESERVED

Á

Operating the HJ3100 is simplicity itself. Merely plug it in, turn it on, and place the ducts and hoods as required for the work station. No adjustment is necessary. The extractors, hoods and ducts are designed to efficiently remove soldering fumes, dust, particles and odors.

Although the Hakko HJ3100 is one of the safest pieces of equipment available, we should like to apprise you of the following:

<p style="text-align: center;">CAUTION.</p> <p style="text-align: center;">READ AND SAVE THESE INSTRUCTIONS BEFORE OPERATING THE HJ3100.</p> <p style="text-align: center;">These basic safety measures must be observed to prevent shock, injury or fire when using electrical devices:</p> <ul style="list-style-type: none">➤ Read these instructions thoroughly before operating the Hakko HJ3100.➤ Do not use this unit to extract flammable or explosive gases.➤ Do not use this unit to extract corrosive materials other than those found in solders and fluxes.➤ Do not expose the power cord to heat, oil or sharp edges.➤ Make sure the main unit is stable and secure.➤ Always switch the Hakko HJ3100 OFF before opening the lid.➤ Use only HAKKO replacement filters.➤ Protect the main unit from moisture.➤ Do not use the HJ3100 to extract water, water vapor or steam.

MAINTENANCE.

The filters are the only parts of the HJ3100 that need maintenance. Figure 3, below, shows the major parts of the HJ3100.

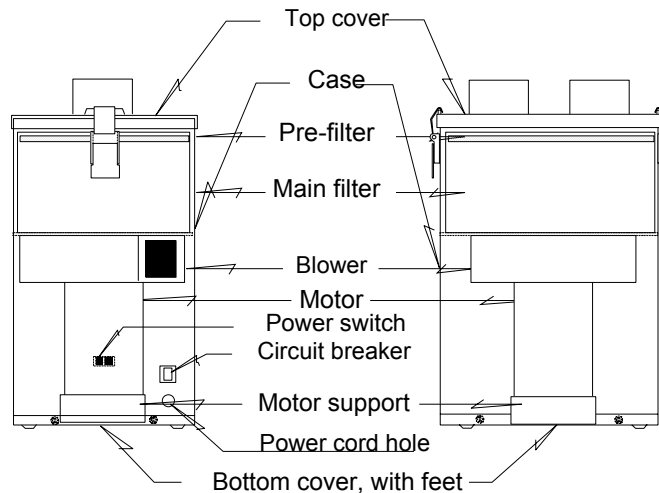

Figure 3.
Illustrated parts breakdown, Hakko HJ3100.

FILTERS.

- The pre-filter should be checked every day under normal operating conditions, and replaced when dirty.
- The HEPA/carbon filter, or activated carbon filter, should be replaced every four months, or 640 hours, in normal use. 'Normal use' is defined as single shift 40-hour week operation.

CAUTION

THE FILTERS CANNOT BE CLEANED.

Do not attempt to clean the pre-filters or primary filters for reuse. Cleaning the filters, save as noted below, will only damage them severely and render them useless. This, in turn, will result in unfiltered air being returned to the environment. Unfiltered air can also damage the motor.⚠

- The particulate filter can be cleaned and reused. It is not necessary to use a pre-filter with the particulate filter. Intervals between cleanings may vary with the application; a good sign that the filter wants cleaning is a loss of air-flow through the pickup accessory. Recommended methods of cleaning are, in order: 1) Vacuum out the debris with a shop vacuum; 2) Blow the accumulated material out with clean dry air; 3) Wash the filter in clean water. If either 2) or 3) is chosen, eye protection is suggested, and the waste must be disposed of according to local regulations.

Hoods and ducts.

- Hoods and ducts should be cleaned periodically to remove accumulated residue. Isopropyl alcohol is recommended for this. The ducts usually require cleaning every four months due to build-up of flux and solder residue inside them. This will become evident to the eye. Inspect flexible ducts for cracks and change them when necessary.

TROUBLE-SHOOTING.

Those occasions when trouble-shooting might be required are rare. However, if certain conditions occur, you may refer to this section. The conditions requiring your attention are:

1. The unit quits running. The power switch is on but nothing happens.
 - a. The motor has overheated. The overtemperature switch will keep it from operating until it has cooled down. This is usually 30 minutes. Meanwhile, you can:
 - i. Check each station. Make sure that the pickup ducts are not blocked.
 - ii. Check the air outlets at the bottom and side of the HJ3100 unit. Make sure they are not blocked.
 - b. There is an electrical problem that has caused a fuse to blow. There is a fuse in the motor/blower unit; later models also have a circuit breaker on the case.
 - i. If the circuit breaker has blown (the reset button is exposed), DO NOT reset until you have checked the wiring for shorts or other defects, including the inadvertent intrusion of foreign objects.
 - ii. Turn the HJ3100 OFF and remove the power plug from the receptacle. See the wiring diagrams in Appendix B to verify integrity of the wiring (that loose wires, disconnected wires, broken wires &c do not exist).
2. The unit runs but does not have any air flow.
 - a. A station (or stations) is (are) blocked.
 - i. See 1 i, ii above.
 - ii. Inspect all flexible ducts. Make sure they are not kinked, blocked, or pinched. If they are, correct the situation or replace the ducts.
 - iii. Inspect the hoods. Make sure they are not blocked or plugged.
 - b. There is an opening in the setup, allowing air to enter the unit.
 - i. Inspect all connections. Tighten or reset where necessary.
 - c. The blower wheel has come adrift from the motor shaft. This has been simulated during test and is exemplified by a marked change in the sound coming from the HJ3100. Instead of the steady whirr of a properly operating unit, it will be a high-pitched whirr accompanied by clanking noises. Should this be suspected:
 - i. Turn the HJ3100 OFF and remove the power plug from the receptacle.

WARNING!!
READ, UNDERSTAND AND SAVE THESE INSTRUCTIONS.
DO NOT ATTEMPT TO OPEN THE HJ3100 WITH POWER APPLIED.
YOU WILL EXPOSE YOURSELF TO SERIOUS INJURY OR DEATH.

- ii. Set the main body on a bench and remove the screws holding the bottom cover.
- iii. Remove the bottom cover.
- iv. Inspect the assembly for structural integrity.

If the blower is loose, close the unit and return it to your Hakko distributor for repair.
- d. The motor/blower does not turn. This becomes evident when there is no air flow and the sound made by the HJ3100 is a hum. If this is suspected, return the HJ3100 to your Hakko distributor for repair.
3. If you encounter a problem that defies solution by these means, call your Hakko representative.

WHERE TO GO FOR SERVICE.

American Hakko Products offers design and installation assistance for HJ3100 customers. Our staff is available to aid you in all aspects of fume extraction.

Should your Hakko HJ3100 ever need service, your local Hakko representative should be able to meet all your needs. For direct assistance, call Customer Service at American Hakko Products:

Telephone: (661) 294-0090
Toll free: (800) 88-HAKKO (884-2556)
Facsimile: (661) 294-0096
E-mail:

Customer Service: support@hakkousa.com

Technical: engineering@hakkousa.com

Marketing: marketing@hakkousa.com

APPENDIX A. FILTERS.

The following filters are available for use in the HJ3100:

PRE-FILTERS.

999-136 pre-filter pad. This is the standard pre-filter supplied with the HJ3100. It captures particles of 1 micron in diameter and larger.

999-201 extended service pre-filter. This accessory is recommended for heavy-duty applications, or where frequent maintenance is difficult. Its effective life is at least 10 times that of the 999-136.

PRIMARY FILTERS.

999-137 HEPA/carbon filter. This is the standard filter supplied with the HJ3100 and is suitable for most operations. A pre-filter is required. Filter efficiency has been determined by tests conducted in accordance with MIL-STD-282 (DOP test); data are available upon request.

999-182 carbon filter. This filter is designed to be used where odor removal is the primary requirement. A pre-filter is required.

999-198 particulate filter. This filter is designed to be used where dust and chip removal is the primary requirement. A pre-filter is not required.

For a complete list of accessories for the Hakko HJ3100, contact your Hakko distributor and request a copy of Hakko publication 2001-FEA-1.

**APPENDIX B.
TECHNICAL INFORMATION.**

©1997, AMERICAN HAKKO PRODUCTS, INC.

ALL RIGHTS RESERVED

Outline drawings.

Figure B-1 is a dimensioned outline drawing of the Hakko HJ3100.

**Figure B-1.
Outline drawings, HJ3100.**

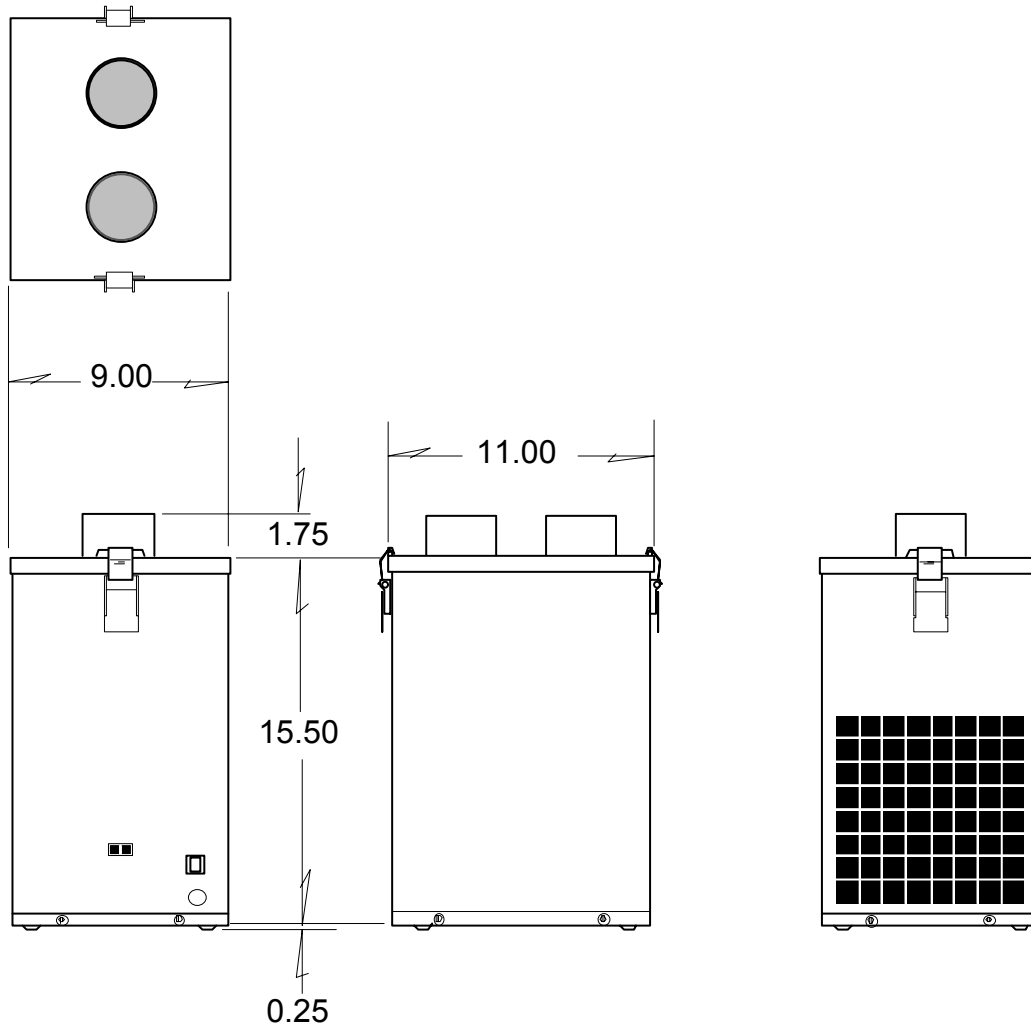

Shown with standard cover, 999-172
Dimensions are the same when 999-173 four-port cover is installed.

WIRING DIAGRAMS.

©1997, AMERICAN HAKKO PRODUCTS, INC.
ALL RIGHTS RESERVED

Á

Several motors have been used in different versions of the HJ3100. For information regarding older units, call Hakko Customer Service and ask for document number 2001-HJ3100-W. Please have the serial number of the unit ready. The information presented in this section now covers only the version in production.

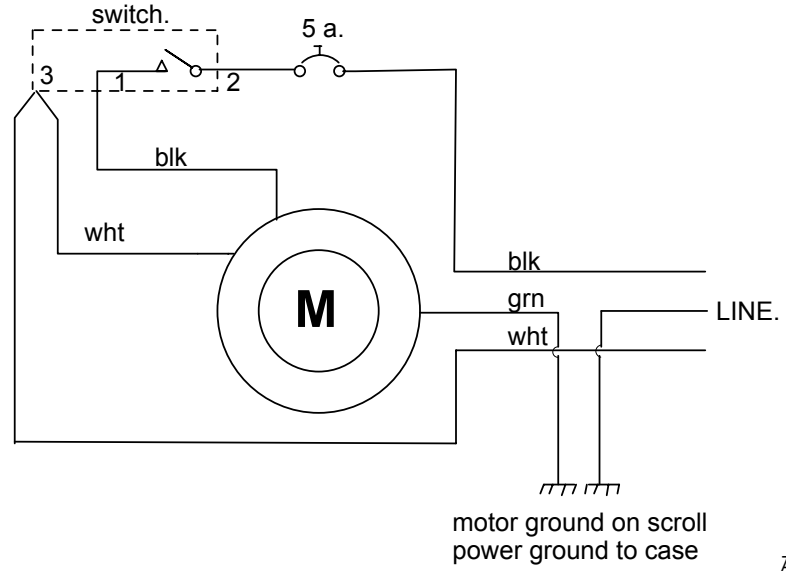

115v

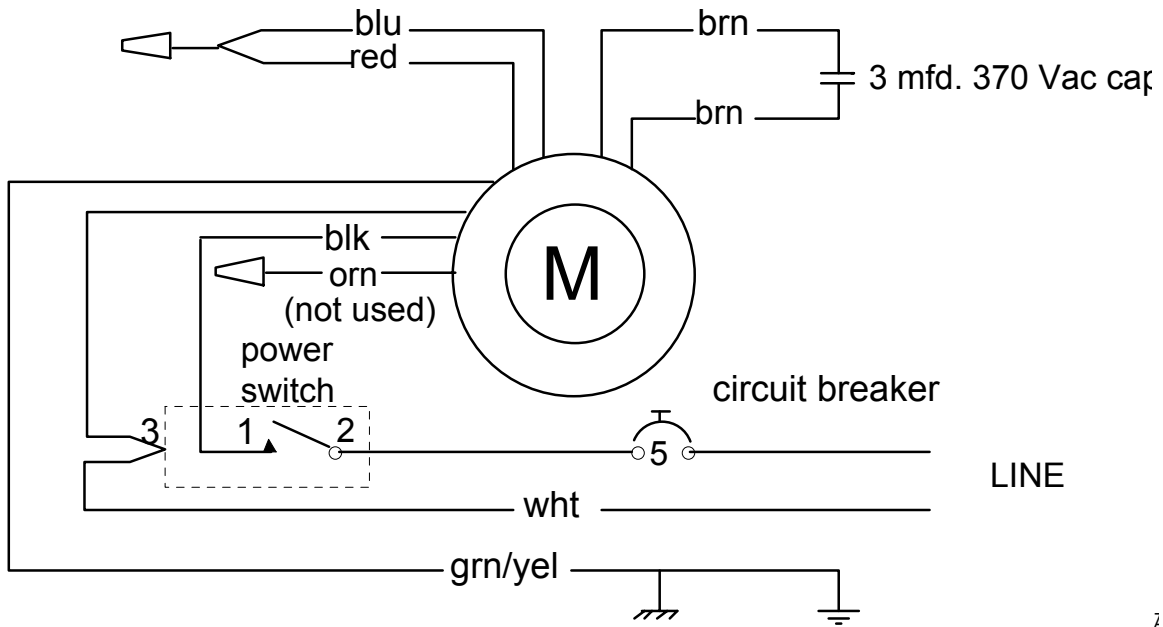

230v.

Figure B-2.
HJ3100 wiring diagrams.

APPENDIX C.

The properties of activated carbon.

The activated carbon odor and gas filter, part no. 999-182, is the same size as the HEPA/carbon filter, part no. 999-137, for

©1997, AMERICAN HAKKO PRODUCTS, INC.

ALL RIGHTS RESERVED

interchangeability in the HJ3100. (It is also the same size as the particulate filter, part no. 999-176, for obvious reasons.)

The activated carbon is made from virgin coconut-shell, with a CCl₄ activity of 60% by weight (CCl₄ = carbon tetrachloride). That means that a test sample of this carbon will adsorb up to 60% by weight of the stuff passed through it. That is why the filter itself is pleated - to subject the air-mass passing through it to the largest possible surface area of carbon. As an estimate, a given volume of air will pass through at least 3 layers of filter material - so that 60% is removed, three times, for an overall adsorption rating greater than 80%.

The net media area of the 999-182 is 13 ft²; the effective adsorption area is 1,950,000 ft² (the 'media' is impregnated with one pound of activated carbon - see below). It is effective on most organic compounds and will collect, by adsorption, approx. 0.2 lb. of vapors. That is a lot of molecules.

A prefilter is required. Carbon will remove *molecules*, not particles!

Activated carbon is the trade name for a carbonaceous adsorbent, defined as follows: Activated carbons are non-hazardous, processed, carbonaceous products, having a porous structure and a large internal surface area. These materials can adsorb a wide variety of substances, i.e. they are able to attract molecules to their internal surface, and are therefore called adsorbents. The volume of pores of the activated carbons is generally greater than 0.2 ml g⁻¹. The internal surface area is generally greater than 400 m² g⁻¹. 453.6 x 400 m² x 10.76 ft²/m² = 1.95 x 10⁶ ft². The width of the pores ranges from 0.3 to several thousand nm. ~~Å~~

TABLE C.

THE RELATIVE ADSORPTIVE ABILITY OF ACTIVATED CARBON AGAINST VARIOUS ODOR SOURCES.

(This is by no means an exhaustive list.)

Column A, adsorptive ability:

E - Excellent; high capacity. One unit of activated carbon will adsorb, on the average, 33.33% of its weight of these compounds.

G - Good; satisfactory adsorption. One unit of activated carbon will adsorb, on the average, 16.67% of its weight of these compounds.

F - Fair; some adsorption. One unit of activated carbon will adsorb less than 10% of its weight of these compounds.

P - Poor. Activated carbon is not suitable for these compounds. ~~Å~~

~~Å~~

Compound	A	Compound	A	Compound	A
Acetic acid	E	Cleaning compounds (most)	E	Phosgene	G
Acetic anhydride	E	Diesel fumes	E	Pitch	E
Amines	F	Essential oils (hair)	E	Pollen	G
Ammonia	F	Eucalyptole	E	Poultry odors	E
Automobile exhaust	G	Fertiliser, organic (manure)	E	Putrefaction	G
Body odors, human	E	Film processing odors	G	Pyridine	E
Borane	G	Fish odors	E	Resins, pine	E
Bromine	E	Flowers	E	Rubber	E
Burnt flesh	E	Formic acid	G	Sauerkraut	E
Burnt food	E	Gangrene	E	Sewer odors	E
Caprylic acid	E	Garlic	E	Skalote	E
Carbolic acid	E	Incense (most)	E	Slaughtering odors	G
Carbon dioxide	P	Iodine	E	Smog	E
Carbon monoxide	P	Iodoform	E	Soldering flux odors	E
Cheese (except chèvre vieux)	E	Kitchen odors, common	E	Sour milk	E
Chlorine	G	Lactic acid	E	Tobacco smoke	E
Citrus	E	Menthol	E	Toilet odors	E

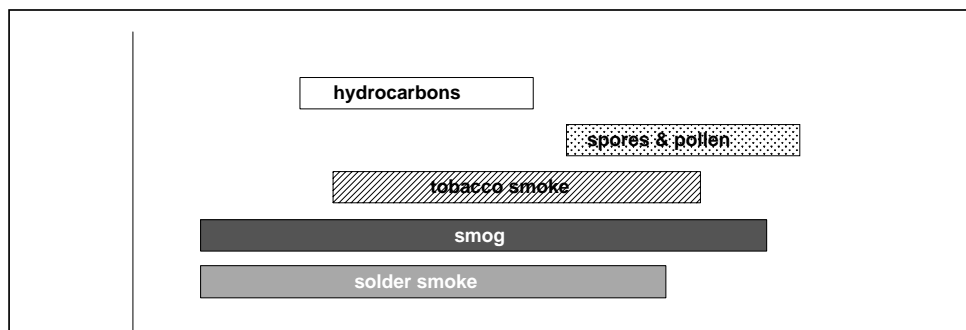

Figure C-1.
Comparison of particle size for
common airborne irritants.

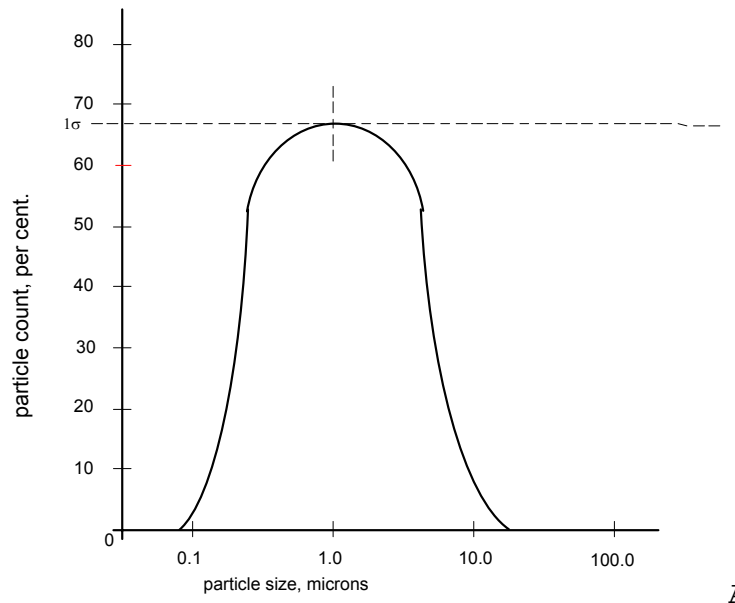

Figure C-2.
Typical distribution of particle size
in solder smoke

APPENDIX D.
WARRANTY.

American Hakko Products, Inc. warrants that all products sold to a buyer will be of new materials and free from defects in material

or workmanship for a period of ninety (90) days.

The validity of requests for warranty repairs or exchanges will be determined by American Hakko Products only.

POWER SUPPLY ELECTRONICS.

Not applicable to the HJ3100.

HEATING ELEMENTS.

Not applicable to the HJ3100.

ALL OTHER ITEMS.

All other items, excluding fuses and circuit breakers, are subject to a ninety (90) day warranty covering materials and workmanship.

PROCEDURES FOR WARRANTY HANDLING.

Repairs will be conducted at and by:

American Hakko Products, Inc.
28920, Avenue Williams
Valencia, California 91355
USA
Telephone: (661) 294-0090
Facsimile: (661) 294-0096

All users of this equipment or parts thereof under the terms of this warranty must obtain a Return Authorization number (RA) from American Hakko Products before the equipment is returned. American Hakko will not accept shipments for repair or warranty service without this number. The sender is responsible for all shipping charges. The buyer of the equipment is solely responsible for providing complete and correct information on the equipment being returned.