

VALUE - LINE

BEVCO

CHAIR ASSEMBLY INSTRUCTION GUIDE

for BEVCO V4/V7/V8 Series Non-Tilt Models

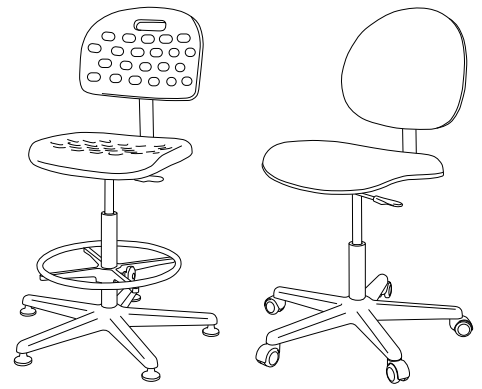

PARTS LIST



Support bar
(1)

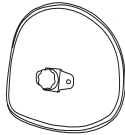

Back Support
w/Integrated
Support Bar
(1)

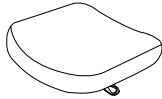

Seat w/control
Mechanism
(1)



Five-star Base
(1)



Pneumatic
Cylinder
(1)



Glides/Casters
(5)

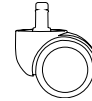

Footring
(optional)
(1)

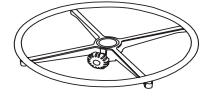

1

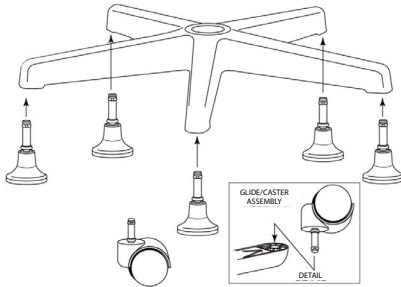

Insert glides or casters into each leg of the base.

2

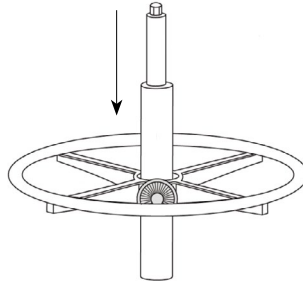

Slide footring (if enclosed) onto cylinder. Ensure the tubular ring faces upward. Tighten handwheel securely.

3

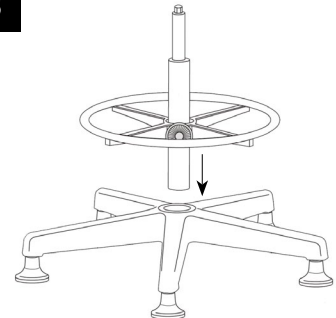

Slide the cylinder into the center of the base.

4

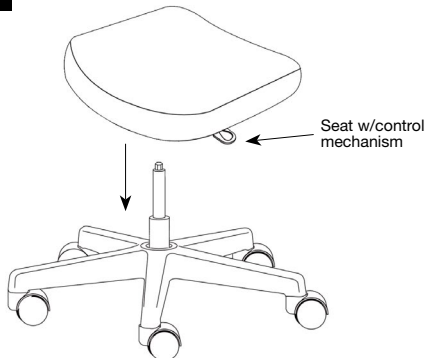

Place seat with control mechanism onto the end of the pneumatic cylinder. Sit on seat to secure fit onto cylinder.

5

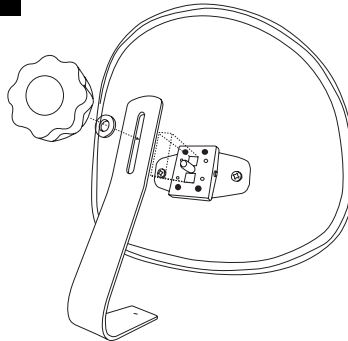

Remove handwheel and white washer from hinge assembly on back. Slide screw through slot in back support bar so it is aligned with the two raised squares on hinge assembly, then position white washer against back bar and then tighten handwheel securely.

6

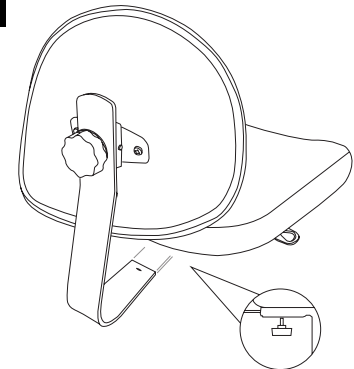

Slide bottom of back support bar into the opening of the control mechanism underneath back of seat. Tighten handwheel securely.